

Public Document Pack



PLANNING COMMITTEE

Tuesday, 22nd July, 2014 at 7.30 pm
Venue: Conference Room,
The Civic Centre, Silver Street,
Enfield, Middlesex, EN1 3XA

Contact: Jane Creer / Metin Halil
Committee Administrator
Direct : 020-8379-4093 / 4091
Tel: 020-8379-1000
Ext: 4093 / 4091
Fax: 020-8379-4455
Textphone: 020 8379 4419
E-mail: jane.creer@enfield.gov.uk
metin.halil@enfield.gov.uk
Council website: www.enfield.gov.uk

MEMBERS

Councillors : Abdul Abdullahi, Lee Chamberlain, Dogan Delman, Christiana During, Christine Hamilton, Ahmet Hasan, Suna Hurman, Derek Levy, Andy Milne, Anne-Marie Pearce, George Savva MBE and Toby Simon (Chair)

N.B. Any member of the public interested in attending the meeting should ensure that they arrive promptly at 7:15pm
Please note that if the capacity of the room is reached, entry may not be permitted. Public seating will be available on a first come first served basis.

Involved parties may request to make a deputation to the Committee by contacting the committee administrator before 12:00 noon on 21/07/14

AGENDA – PART 1

10. **P14-02068PLA - UNIT 1A, CROWN ROAD, ENFIELD, EN1 1TH** (Pages 1 - 18)

RECOMMENDATION: Approval subject to conditions
WARD: Southbury

SENT TO FOLLOW

This page is intentionally left blank

LONDON BOROUGH OF ENFIELD

PLANNING COMMITTEE

Date : 22nd July 2014

Report of
Assistant Director -
Planning, Highways &
Transportation

Contact Officer:
Andy Higham Tel: 020 8379 3848
Sharon Davidson Tel: 020 8379 3841
Sean Newton Tel: 020 8379 3851

Ward:
Southbury

Application Number : P14-02068PLA

Category: Major

LOCATION: Unit 1a Crown Road, Enfield, Middlesex, EN1 1TH

PROPOSAL: Proposed 3,131sqm mezzanine floor (1,041sqm extension of 2,090sqm mezzanine already approved under P13-03855PLA)

Applicant Name & Address:
Universities Superannuation Scheme
c/o Agent

Agent Name & Address:
Colin Burnett
Golden Cross House
8 Duncannon Street
London
WC2N 4JF

RECOMMENDATION:

It is recommended that planning permission is **GRANTED** subject to conditions.

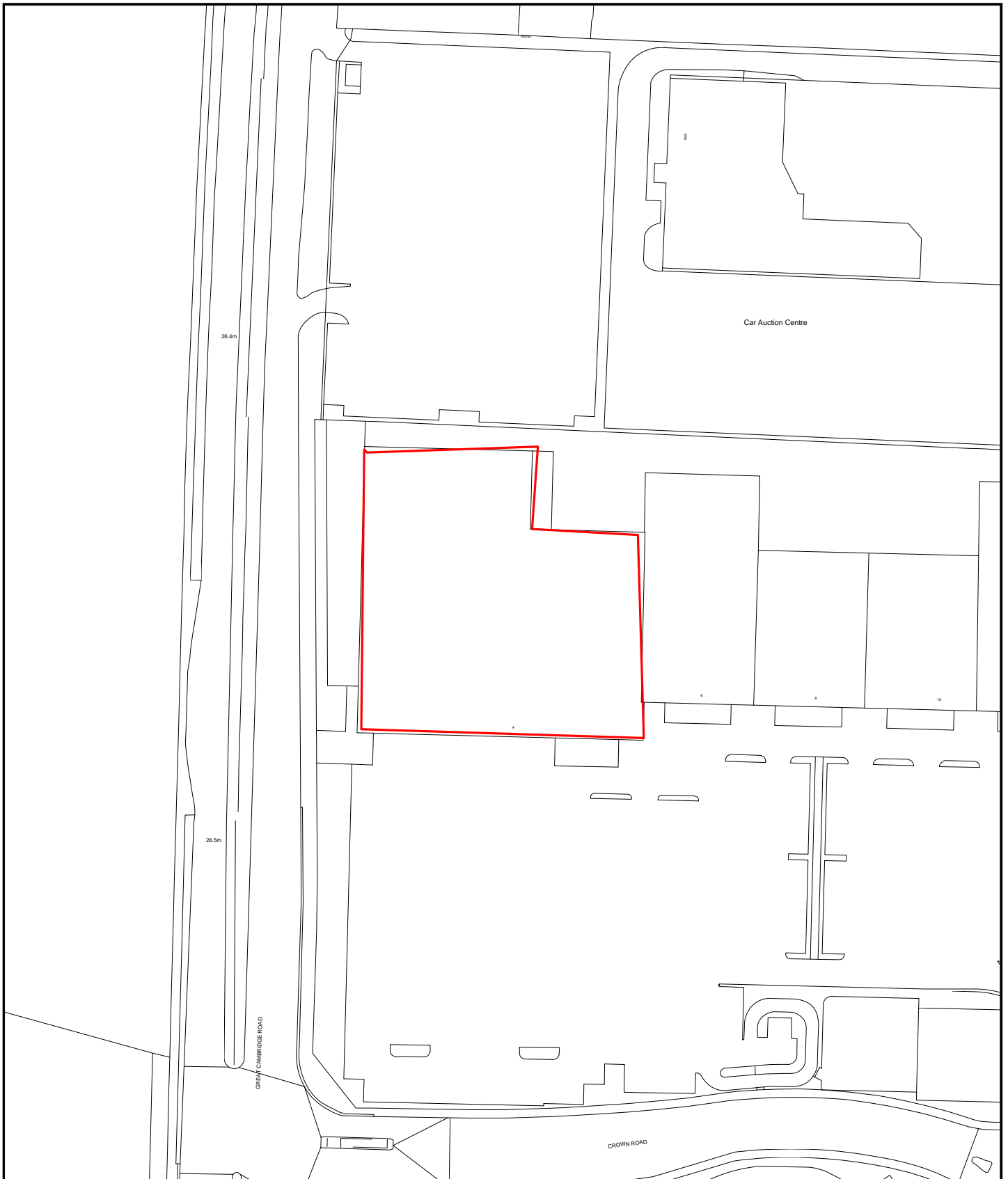

Development Control



Scale - 1:1250
Time of plot: 15:47 Date of plot: 15/07/2014

1 Site and Surroundings

- 1.1 The application site is located on the eastern side of The Great Cambridge Road (A10), at the northern end of a car park on the southbound carriageway, within the Enfield Retail Park.

2 Proposal

- 2.1 Permission is sought for a proposed 3,131sqm mezzanine floor (1,041sqm extension of 2,090sqm mezzanine already approved under P13-03855PLA).

3 Planning History

- 3.1 There are numerous planning applications relating to the Retail Park. The most relevant are detailed below:

Applications relating to the application site (Unit 1A):

- 3.2 Planning permission (ref: P13-03855PLA) was granted in April 2014 for the construction of mezzanine to No. 4 (Unit 1A) to provide 2,090sq.m. of retail floor space with ancillary storage and removal of mezzanine floors within No's. 6 & 12 (Units 2 & 5).
- 3.3 In March 2013, permission was granted (ref: P12-02983PLA) for the variation of condition 1 of P12-00857PLA to include the sale of clothing and footwear. The revised condition was worded thus:

The retail units hereby approved shall only be used for the sale of non-food bulky goods comprising DIY/hardware, furniture, furnishings, carpets, floor coverings, household textiles, motor vehicle and/or cycle goods, electrical and electronic goods including telecommunications, baby and toddler related goods, pets and pet products (including pet food, pet supplies and pet services), the sale of books and newspapers and magazines limited to the publications which are ancillary to the type of goods restricted by this condition. The sale of clothing and footwear shall also be permitted in Unit 1A only.
Reason: To ensure that the retail activity and sales from the premises do not prejudice the viability of the established shopping centres in the Borough having regard to the objectives of the Local Plan and national guidance contained within the National Planning Policy Framework.

- 3.4 In May 2012, planning permission was granted for a variation of condition 15 of permission TP/10/0480 to include sale of baby and toddler related goods (ref: P12-00857PLA).

Applications relating to the Retail Park:

- 3.5 Planning permission (ref: TP/91/0110) was granted in July 1992 for the redevelopment of land at 540-580 Great Cambridge Road by the erection of a retail store (A1) (7060 sq. metres gross floor space) together with coffee shop (A3); automatic teller facilities and petrol filling station; erection of retail warehouse units (15 338 sq. metres gross floor space); erection of restaurant (A3); erection of buildings for B1 or B2 use (5 462 sq. metres gross floor space); erection of a building for B1 use (3,458 sq.metres gross floor space); relocation of electricity sub-station; provision of ancillary parking and service

areas; and associated highway and landscaping works was granted in January 1991.

Condition 29 of the above application stated the following: *That the proposed retail units the subject of this planning permission shall not be subdivided and/or the floor spaces increased unless agreed in writing by the Local Planning Authority.*

- 3.6 In January 2000, Planning Permission was granted (ref: TP/91/0110/07) for the creation of a new retail unit within existing premises for sale of pharmaceuticals and ancillary products, related to a chemist store including health and dietary foods, baby and young children's products and photographic processing/sale of associated products.
- 3.7 In May 2003, Planning Permission was granted for the variation of condition 28 to allow installation of mezzanine floor to provide additional 49sqm of retail floor space (ref: TP/91/0110/10).
- 3.8 In July 2003 an application (ref: TP/91/0110/10) for the variation of Condition 28 attached to planning permission under Ref: TP/91/0110 to enable the installation of a mezzanine floor was granted planning permission.
- 3.9 In October 2009, Planning Permission was granted (ref: TP/91/0110/12) for the creation of a new retail unit within existing premises for sale of pharmaceuticals and ancillary products, related to a chemist store including health and dietary foods, baby and young children's products and photographic processing/sale of associated products.
- 3.10 In October 2013, permission was granted for the erection of three single storey units for A1/A3 use including external seating area to north of site, plant to roof. Installation of bollards and fencing to perimeter, reconfiguration of car parking, new pedestrian access, landscaping and security barrier, covered cycle parking (ref: P13-02159PLA).

4 Consultations

4.1 Statutory and non-statutory consultees

LBE Traffic & Transportation

4.1.1 The following has been advised:

- Access remains unchanged.
- There are 600 parking spaces serving the retail park and 200 readily available on average.
- Servicing will continue as existing.
- Previously submitted parking data from the earlier mezzanine application is still relevant.
- Concerns that the site is being overdeveloped and the net development over time could prejudice parking availability and have a negative impact on the wider network.
- No objection as the development is unlikely to result in conditions prejudicial to either parking provision or highway safety.

Sustainable Design Officer

4.1.2 It has been advised that the emerging DMD policies require the utilisation of the roof space for LZC and that DEN connection is also possible to the site.

4.2 **Public response**

4.2.1 Letters were sent to the occupiers of 6 adjoining properties in addition to statutory publicity. No comments have been received.

5 **Relevant Policy**

5.1 The National Planning Policy Framework (NPPF) published in March 2012 allowed local planning authorities a 12 month transition period to prepare for the full implementation of the NPPF. Within this 12 month period local planning authorities could give full weight to the saved UDP policies and the Core Strategy, which was adopted prior to the NPPF. The 12 month period has now elapsed and as from 28th March 2013 the Council's saved UDP and Core Strategy policies will be given due weight in accordance to their degree of consistency with the NPPF.

5.2 The Development Management Document (DMD) policies have been prepared under the NPPF regime to be NPPF compliant. The submission version DMD was approved by Council on 27th March 2013 and has now been submitted for examination to the Secretary of State. Hearing sessions are scheduled for late April and the examination period is anticipated to run through to the end of summer of 2014. The DMD provides detailed criteria and standard based polices by which planning applications will be determined.

5.3 The policies listed below are considered to be consistent with the NPPF and therefore it is considered that due weight should be given to them in assessing the development the subject of this application.

5.4 The London Plan

Policy 2.7	Outer London: Economy
Policy 2.15	Town Centres
Policy 4.7	Retail and Town Centre development
Policy 4.8	Supporting a Successful and diverse retail centre
Policy 5.1	Climate change mitigation
Policy 5.2	Minimising carbon dioxide emissions
Policy 5.3	Sustainable design and construction
Policy 5.5	Decentralised energy networks
Policy 5.6	Decentralised energy in development proposals
Policy 5.7	Renewable energy
Policy 5.8	Innovative energy technologies
Policy 5.9	Overheating and cooling
Policy 5.10	Urban greening
Policy 5.11	Green roofs and development site environs
Policy 5.13	Sustainable drainage
Policy 5.14	Water quality and wastewater infrastructure
Policy 6.3	Assessing the effects of development on transport capacity
Policy 6.9	Cycling
Policy 6.12	Road network capacity
Policy 6.13	Parking

Policy 7.2	An inclusive environment
Policy 7.3	Designing out crime
Policy 7.4	Local character
Policy 7.6	Architecture
Policy 7.14	Improving air quality
Policy 7.15	Reducing noise and enhancing soundscapes
Policy 7.19	Biodiversity and access to nature

5.5 Local Plan

CP13:	Promoting economic prosperity
CP18:	Delivering shopping provision across Enfield
CP20:	Sustainable energy use and energy infrastructure
CP21:	Delivering sustainable water supply, drainage and sewerage infrastructure
CP22:	Delivering sustainable waste management
CP24:	The road network
CP25:	Pedestrians and cyclists
CP26:	Public transport
CP30:	Maintaining and improving the quality of the built and open environment
CP32:	Pollution
CP36:	Biodiversity
CP46:	Infrastructure contributions

5.6 Saved UDP Policies

(II)GD3	Design
(II)GD6	Traffic generation
(II)GD8	Access and servicing
(II)S17	New retail development outside of town centres

5.7 Submission Version DMD

DMD25	Locations for New Retail, Leisure and Office Development
DMD26	Enfield Town
DMD32	Managing the Impact of Food and Drink Establishments
DMD37	Achieving High Quality Design-Led Development
DMD38	Design Process
DMD40	Ground Floor Frontages
DMD44	Preserving and Enhancing Heritage Assets
DMD45	Parking Standards
DMD47	New Roads, Access and Servicing
DMD48	Transport Assessments
DMD49	Sustainable Design and Construction Statements
DMD50	Environmental Assessment Methods
DMD51	Energy Efficiency Standards
DMD52	Decentralised Energy Networks
DMD53	Low and Zero Carbon Technology
DMD54	Allowable Solutions
DMD55	Use of Roof Space / Vertical Surfaces
DMD56	Heating and Cooling
DMD57	Responsible Sourcing of Materials
DMD58	Water Efficiency
DMD59	Avoiding and Reducing Flood Risk

DMD60	Assessing Flood Risk
DMD61	Managing Surface Water
DMD64	Pollution Control and Assessment
DMD65	Air Quality
DMD66	Land Contamination and Instability
DMD68	Noise
DMD69	Light Pollution
DMD78	Nature Conservation
DMD79	Ecological Enhancements
DMD80	Trees on Development Sites
DMD81	Landscaping

5.8 Other Relevant Considerations

National Planning Policy Framework (NPPF)
National Planning Practice Guidance (NPPG)
Section 106 Supplementary Planning Document

6 **Analysis**

6.1 Principle

- 6.1.1 At its core, the NPPF has a presumption in favour of sustainable development. This is to be achieved through, amongst other considerations, placing “significant weight... on the need to support economic growth through the planning system” (para.19). It also advises at Section 2, that Local Plans should recognise town centres as the heart of the community and policies should be pursued to support their viability and vitality (para. 23).
- 6.1.2 Policy DMD25 (Locations for new retail, leisure and office development) confirms that new development within the existing retail parks will only be permitted if the applicant has satisfactorily demonstrated that:
- through a sequential test, there are no more suitable sites available within or on the edge of the town centres;
 - a retail impact assessment has demonstrated that there is not likely to be a negative impact to the vitality and viability of Enfield’s centres or planned investment in centres; and
 - the development increases the overall sustainability and accessibility of the retail park in question.
- 6.1.3 Condition 28 of the original permission relating to the development for a retail park (ref: TP/91/0110) restricted the creation of additional floor space or the subdivision of a building. This was to control floor space that could be provided in order for the Council to be satisfied that its car parking standards are being met and ensure that the proposed development does not prejudice the free flow of traffic or conditions of general safety along the neighbouring highways.
- 6.1.4 The mezzanine floor space to be created within Unit 1A by virtue of planning application P13-03855PLA has not yet been implemented.

6.2 Impact on Existing Centres

Applicant’s Evidence:

- 6.2.1 Against the Policy background outlined above, a Retail Assessment has been submitted which demonstrates that there is no significantly adverse impact on Enfield Town Centre in particular.
- 6.2.2 The applicant contends that the proposal represents less than a 6% increase on existing floor space within the Retail Park and is unlikely to have a significant effect on the established role and function of the Retail Park (para.4.1 Retail Assessment, May 2014). Based upon a sales density of £2500 per sqm net for a bulky goods retailer, the already permitted 2090sqm of mezzanine floor space is estimated to have a potential annual turnover of £4.4M or 1.9% of the £228.4M identified capacity in the period to 2022. The turnover attributable to the additional mezzanine floor space is estimated to be £2.2M or 1% for the same period. The cumulative impact of the permitted and proposed floor space would represent a trade diversion of £3.3M and an impact of 1.3% on Enfield Town Centre.
- 6.2.3 A health check of Enfield Town Centre reveals that the Town Centre is “vital and vibrant” with a strong range in the choice of comparison goods retailers and comparison goods floor space significantly above the UK averages. Comparison goods turnover within Enfield Town Centre is £211.5M at 2009 (in 2007 prices), or £210M in 2010 prices. In 2017, it is estimated that the comparison goods turnover for Enfield Town Centre would be at least £206.8M.
- 6.2.4 Having regard to the above, it is the applicants’ contention that the development will not have a significant effect on the capacity for additional floor space in the Borough or have a significant adverse impact on planned investment in Enfield Town. There are also no suitable opportunities to accommodate the type of business model offered by Unit 1A. In addition, it is contended that the proposal allows for greater flexibility for future re-letting, thus protecting against future vacancy, and it will allow for a more intensive use of the existing unit thus meeting with sustainable planning objectives and retail needs.

LPA’s Evidence:

- 6.2.5 To test the above assumptions, consultants Nathaniel Litchfield & Partners were commissioned to provide a critique of the submitted Retail Assessment.
- 6.2.6 Although the sales density calculation is not unreasonable for a bulky goods retailer, the imposed condition restricting the range of goods that can be sold allows for a significant level of flexibility and includes clothing and fashion. This would potentially attract a retailer such as Next At Home, thus attracting a higher sales density, which should also be tested as a worse-case scenario. Mintel’s Retail Rankings 2013 suggests a sales density of £4000 per sqm inclusive of VAT, thereby attracting an estimated turnover of £10.6M for the extant permission for a mezzanine floor and the additional floor space proposed.
- 6.2.7 It is estimated that total comparison goods turnover within the Borough will increase by 8.4% from £732.41M in 2014 to £794.45M in 2017 as a result of population and expenditure growth. In Enfield Town Centre alone, it is estimated that there will be an increase of 8.5% for the same period, representing an increase from an estimated £429.85M to £466.3M.

Projections indicate that there will be sufficient expenditure growth to allow a 2% growth in turnover efficiency for existing retail floor space in Enfield Town and the occupation of vacant units. The level of trade diversion is not expected to lead to shop closures with the Enfield Town.

6.2.8 It is also estimated that the proportional impact on comparison goods shopping destinations in the Borough will range from -0.2% to -1.4%. It is also estimated that the greatest impact will be on Enfield Town Centre (-1.4%), as opposed to the estimated -1.5% from the Applicant. It should be noted that two thirds of the estimated trade diversion (£4.3M) will occur if the extant permission is implemented.

6.2.9 A health check of Enfield Town Centre demonstrates the following:

Strengths:

- There is a good range of national multiple and independent comparison retailers in a pleasant pedestrianized environment.
- There is a good selection of multiple convenience retailers for main food and top-up shopping, supported by good quality independent traders.
- The market adds to the retail provision.
- The Centre's vacancy rate is lower than the national average.
- The centre has excellent transport links within the Borough and to central London.

Weaknesses:

- Narrow footpaths along some streets making the area feel crowded.
- A reasonable amount of traffic congestion within the main road junction.
- The proportion of betting shops and pay day loan shops is much higher than the national average.

6.2.10 Whilst the Applicant's Retail Study does not consider potential sites in other centres (e.g. Edmonton Green, Palmers Green, Southgate), it is agreed that there are no large scale opportunities in any designated centres. It should be noted that a 2007 study identified 11 potential sites within designated Town Centres. Five of the sites were rated as having a reasonable to good development prospects but they only had a combined capacity of approximately 3000sqm.

6.2.11 Having regard to all of the above, it is concluded that the cumulative floor space proposed by the extant planning permission for 2090sqm of mezzanine floor space and the proposed additional 1041sqm of mezzanine floor space will not have a significantly adverse impact on the vitality and viability of existing centres, in particular Enfield Town Centre, having regard to Core Policies 13 & 18 of the Core Strategy, Policy (II)S17 of the Unitary Development Plan, Policies 2.7, 2.15, 4.7 & 4.8 of the London Plan, with Policies 25, 26 & 32 of the Submission version Development Management Document and with national guidance contained within the National Planning Policy Framework (in particular sections 1 and 2).

6.3 Impact on Character of Area

6.3.1 The proposed works are internal and will therefore not affect the appearance of the building or the appearance of the Retail Park.

6.4 Highway Safety

- 6.4.1 Submitted parking surveys demonstrate that on average, there were approximately 200 free spaces available at any one time within the Retail Park. The development will not result in the loss of any parking spaces. The creation of additional retail floor space could potentially increase the trip rate of the site, however it is considered that it would be unlikely to be at a level that would compromise the operation of the car park.
- 6.4.2 Whilst the proposed development will not prejudice parking or result in any negative impact on the wider highway network, any future development would need to be carefully assessed to ensure there are no negative impacts.
- 6.4.3 The proposed development provides acceptable car parking and servicing arrangements and would not give rise to conditions prejudicial to the free flow and safety of traffic within the existing car park or on the adjoining highways, having regard to Policies (II)GD6 and (II)GD8 of the Unitary Development Plan and Policy 6.13 of the London Plan, and with Policies 45, 47 & 48 of the Submission Version Development Management Document.

6.5 Sustainable Design & Construction

Energy / BREEAM

- 6.5.1 The quantum of development is noted, although the entirety of the development proposed is internal. Having regard to this and also to the tests to be applied in the use of conditions as set out in the NPPG (Use of Planning Conditions), it was considered reasonable on the previous application to secure details of the feasibility of using low or zero carbon technology in accordance with DMD51 of the Submission Version DMD.
- 6.5.2 The current proposal is supported by an Energy Statement that indicates that the development will achieve a 40% reduction over Part L of the 2010 Building Regs through an energy efficient & electrical design and a 120sqm solar photovoltaic array. A condition is therefore proposed to secure the implementation of the energy saving measures identified.

Construction Site Waste Management Plan

- 6.5.3 Policy 5.16 of the London Plan has stated goals of working towards managing the equivalent of 100% of London's waste within London by 2031, creating benefits from waste processing and zero biodegradable or recyclable waste to landfill by 2031. This will be achieved in part through exceeding recycling and reuse levels in construction, excavation and demolition (CE&D) waste of 95% by 2020.
- 6.5.4 In order to achieve the above, London Plan policy 5.18 confirms that through the Local Plan, developers should be required to produce site waste management plans (SWMP) to arrange for the efficient handling of construction, excavation and demolition waste and materials. Core policy 22 of the Core Strategy states that the Council will encourage on-site reuse and recycling of CE&D waste.
- 6.5.5 No information has been provided, therefore a condition will be imposed to secure a SWMP that complies with adopted policies.

Biodiversity / Ecology

- 6.5.6 CP36 of the Core Strategy confirms that all developments should be seeking to protect, restore, and enhance sites. The site, due to its extensive hard-surfaced areas, its location, and a small amount of plantings (inclusive of trees), has a low ecological value.
- 6.5.7 As discussed above, the entirety of the development is internal, therefore in this instance it is not considered necessary to impose a condition seeking such improvements.

6.6 Mayoral Community Infrastructure Levy (CIL)

- 6.6.1 The Mayoral CIL is collected by the Council on behalf of the Mayor of London. The amount that is sought for the scheme is calculated on the net increase of gross internal floor area multiplied by the Outer London weight of £20. In addition, the index figure for April is 238.
- 6.6.2 The development is considered to be CIL liable on the additional floor space (1041sqm), although it would be up to the applicant to apply for any relief. The CIL calculation is: $(£20/\text{sqm} \times 1041\text{sqm} \times 234)/223 = £21,846.96$.

6.7 Conclusion

- 6.7.1 Having regard to all of the above, it is considered that planning permission should be granted subject to the following conditions:

1. C60 Approved Plans
2. C51A Time Limited Permission
3. NSC1 Restriction of Retail Goods
The sale of retail goods permitted from the approved mezzanine floor shall be restricted to the goods permitted for sale within the existing Unit 1a. This will include the sale of clothing, footwear, non-food bulky goods comprising DIY/hardware, furniture, furnishings, carpets, floor coverings, household textiles, motor vehicle and/or cycle goods, electrical and electronic goods including telecommunications, baby and toddler related goods, pets and pet products (including pet food, pet supplies and pet services), and the sale of books and newspapers and magazines shall be limited to the publications which are ancillary to the type of goods restricted by this condition.

Reason: To ensure that the retail activity and sales from the premises do not prejudice the viability of the established shopping centres in the Borough, it is consistent with the types of goods that can be sold within Unit 1a as permitted by planning reference p12-02983PLA, and having regard to the objectives of the Local Plan and national guidance contained within the National Planning Policy Framework.

4. C46 No Subdivision
The additional mezzanine floor space hereby approved within Unit 1a shall only be occupied in connection with the

previously approved mezzanine floor space (ref: P13-03885PLA) and the ground floor use and the unit shall not be subdivided unless otherwise agreed in writing by the Local Planning Authority.

Reason: To ensure that the quantum of retail space, retail activity and sales from the Enfield Retail Park do not prejudice the viability of the established shopping centres in the Borough, having regard to the objectives of the Local Plan and national guidance contained within the National Planning Policy Framework, and having regard to adopted parking and servicing standards.

5. NSC4 No Additional Mezzanine Floor Provision
Notwithstanding the provisions of the Town and Country Planning (General Permitted Development) Order 1995 ("the 1995 Order") (or any order revoking and re-enacting the 1995 Order with or without modification), no mezzanine floor space shall be provided within Units 2 & 5 as identified on Drawing No.URB U1[08]0011 Rev.D00 without the prior written approval of the Local Planning Authority.

Reason: To ensure that the quantum of retail space, retail activity and sales from the Enfield Retail Park do not prejudice the viability of the established shopping centres in the Borough, having regard to the objectives of the Local Plan and national guidance contained within the National Planning Policy Framework, and having regard to adopted parking and servicing standards.

6. NSC5 Restriction of Use of Approved Mezzanine Floor
The additional mezzanine floor space approved by this permission and the extant planning permission (ref: P13-03855PLA) shall not be used whatsoever until written confirmation has been provided to the Local Planning Authority that the existing mezzanine floors within Units 2 & 5 as identified on Drawing No.URB U1[08]0011 Rev.D00 have been removed.

Reason: To ensure that the quantum of retail space, retail activity and sales from the Enfield Retail Park do not prejudice the viability of the established shopping centres in the Borough, having regard to the objectives of the Local Plan and national guidance contained within the National Planning Policy Framework.

7. NSC6 Energy
The development shall achieve energy efficiency savings of no less than a 40% improvement on 2010 Building Regulations as identified within the submitted Energy Statement (May 2014), unless otherwise approved in writing by the Local Planning Authority.

Reason: In the interest of addressing climate change and to secure sustainable development in accordance with adopted Policy.

8. NSC7

Renewable Energy Provision

The renewable energy technologies (photovoltaics) identified within the submitted Energy Statement (May 2014) shall not be installed until such time as the details have been submitted to and approved in writing by the Local Planning Authority. The details shall include:

- (a) The resulting scheme, together with any machinery/apparatus location, specification and operational details;
- (b) A management plan and maintenance strategy/schedule for the operation of the technologies; and
- (c) A servicing plan including times, location, frequency, method.

The renewable energy technologies (photovoltaics) shall be installed in accordance with the approved details and operational prior to the first occupation or use of the development approved and shall be maintained as such thereafter, unless otherwise approved in writing by the local Planning Authority.

Reason: In the interest of sustainable development and to ensure that the Local Planning Authority may be satisfied that CO2 emission reduction targets by renewable energy are met in accordance with adopted policy.

9. NSC8

Construction Waste Management Plan

The development shall not commence until a Construction Waste Management Plan has been submitted to the Local Planning Authority for approval in writing. The plan should include as a minimum:

- i. Target benchmarks for resource efficiency set in accordance with best practice
- ii. Procedures and commitments to minimize non-hazardous construction waste at design stage. Specify waste minimisation actions relating to at least 3 waste groups and support them by appropriate monitoring of waste.
- iii. Procedures for minimising hazardous waste
- iv. Monitoring, measuring and reporting of hazardous and non-hazardous site waste production according to the defined waste groups (according to the waste streams generated by the scope of the works)
- v. Procedures and commitments to sort and divert waste from landfill in accordance with the waste hierarchy (reduce; reuse; recycle; recover) according to the defined waste groups

In addition no less than 85% by weight or by volume of non-hazardous construction, excavation and demolition waste generated by the development has been diverted from landfill

Reason: To maximise the amount of waste diverted from landfill consistent with the waste hierarchy and strategic targets set by Policies 5.17, 5.18, 5.19, 5.20 of the London Plan.

10. NSC9

Construction Methodology

That development shall not commence until a construction methodology has been submitted to and approved in writing by the Local Planning Authority. The construction methodology shall contain:

- a. details of construction access and associated traffic management to the site;
- b. arrangements for the loading, unloading and turning of delivery, construction and service vehicles clear of the highway;
- c. arrangements for the parking of contractors vehicles;
- d. the erection and maintenance of security hoarding including decorative displays and facilities for public viewing, where appropriate
- e. arrangements for the storage of materials;
- f. hours of work;
- g. A construction management plan written in accordance with the 'London Best Practice Guidance: The control of dust and emission from construction and demolition';
- h. size and siting of any ancillary buildings.

The development shall be carried out in accordance with the approved construction methodology unless otherwise agreed in writing by the Local Planning Authority.

Reason: To ensure the implementation of the development does not lead to damage to the existing highway and to minimise disruption to neighbouring properties and the environment.

Copyright of the drawings is the property of Urban Edge Architecture Limited. It must not be reproduced or amended without the express consent in writing of Urban Edge Architecture Limited.

Urban Edge Architecture Limited
 One Scroggie Mews, Scroggie,
 Stirling, FK8 2JG
 Tel: +44 (0)1799 735565
 Fax: +44 (0)1799 735566

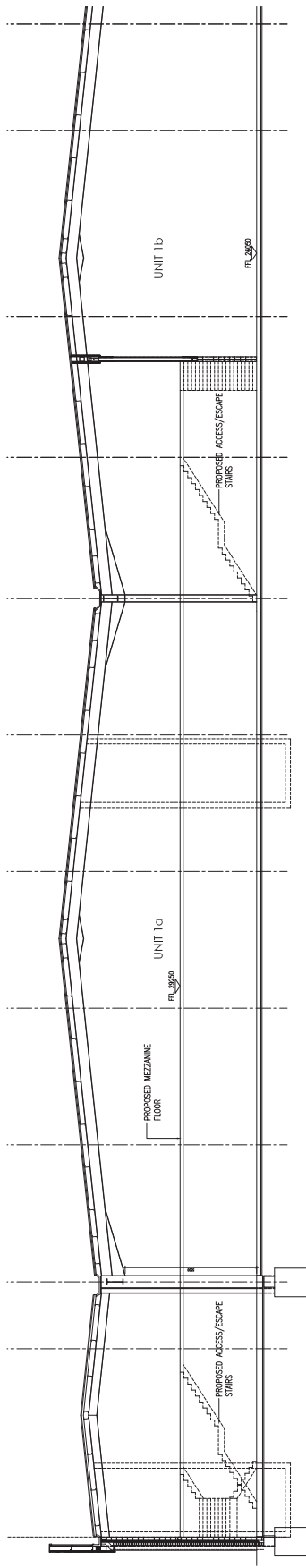

CROSS SECTION (EAST/WEST) - 1:100

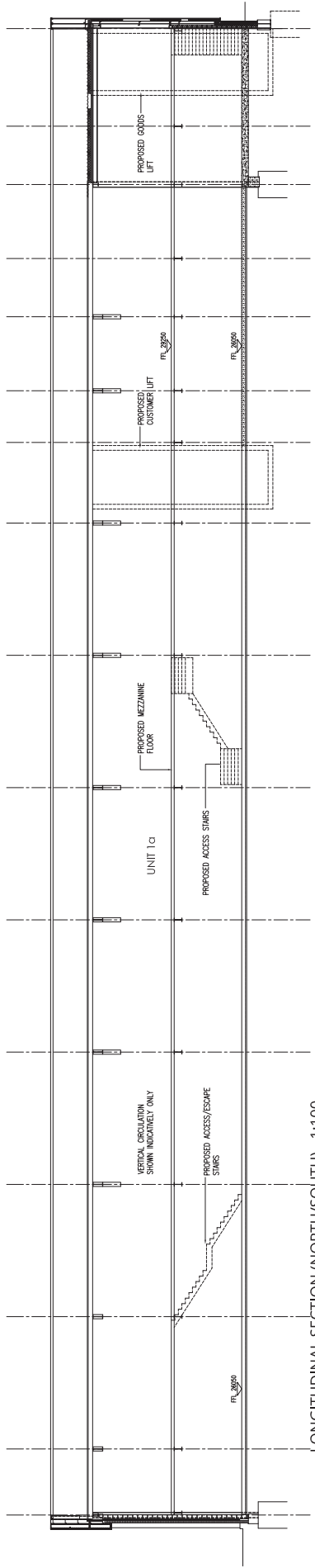

LONGITUDINAL SECTION (NORTH/SOUTH) - 1:100

Revision	Description	Date
URBANEDGE ARCHITECTURE AND PLANNING		
Client	UNIVERSITIES SUPERANNUATION SCHEME	
Project	ENFIELD RETAIL PARK UNIT 1A	
Drawn By	1348_URB_01	
Checked By	1348_URB_01	
Date	MAY 14	
Project No.	Drawing No.	
Scale	Drawing Title	
PROPOSED SECTIONS SHOWING MEZZANINE UNIT 1a		
1348_URB_01 [08] 80 11 D00		

Copyright of the drawings is the property of Urban Edge Architecture Limited. It must not be reproduced or amended without the express consent in writing of Urban Edge Architecture Limited.

Urban Edge Architecture Limited
 One Stogates Mews, Stogates
 Stamford, Leicestershire LE8 3JX
 Tel: +44 (0)1533 755565
 Fax: +44 (0)1533 755566
 For information only

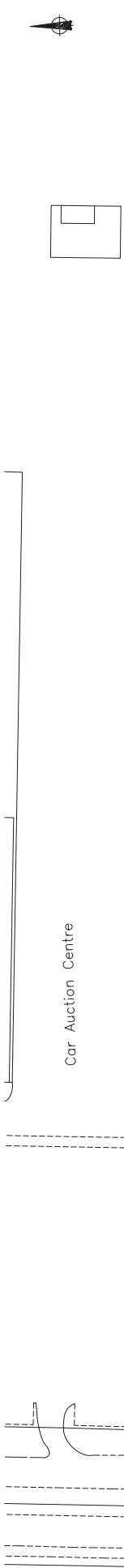

Revision	Description	Date
URBANEDGE ARCHITECTURE & PLANNING		
Client	UNIVERSITIES SUPERANNATION SCHEME	
Project	ENFIELD RETAIL PARK UNIT 1a	
Drawn By	PROPOSED SITE BLOCK PLAN	
Scale	1:500 (A1)	Drawn: TM
Date	MAY 14	Project No. Drawing No.
1348_URB UT [08] 00 13		Revision
D00		

Copyright of this drawing is the property of Urban Edge Architecture Limited. It must not be reproduced or amended in any form without the express consent in writing of Urban Edge Architecture Limited.

Urban Edge Architecture Limited
One Scogate Mews, Scogate,
Stamford, Lincolnshire, PE9 2PX.
Tel. +44 (0)1780 755 665
Fax. +44 (0)1780 739 360
For information only

SITE ADDRESS:
UNIT 1a
ENFIELD RETAIL PARK
CROWN ROAD, ENFIELD
EN1 1TH

LEGEND:
— RED LINE APPLICATION BOUNDARY
— ADJACENT OWNERSHIP BOUNDARY

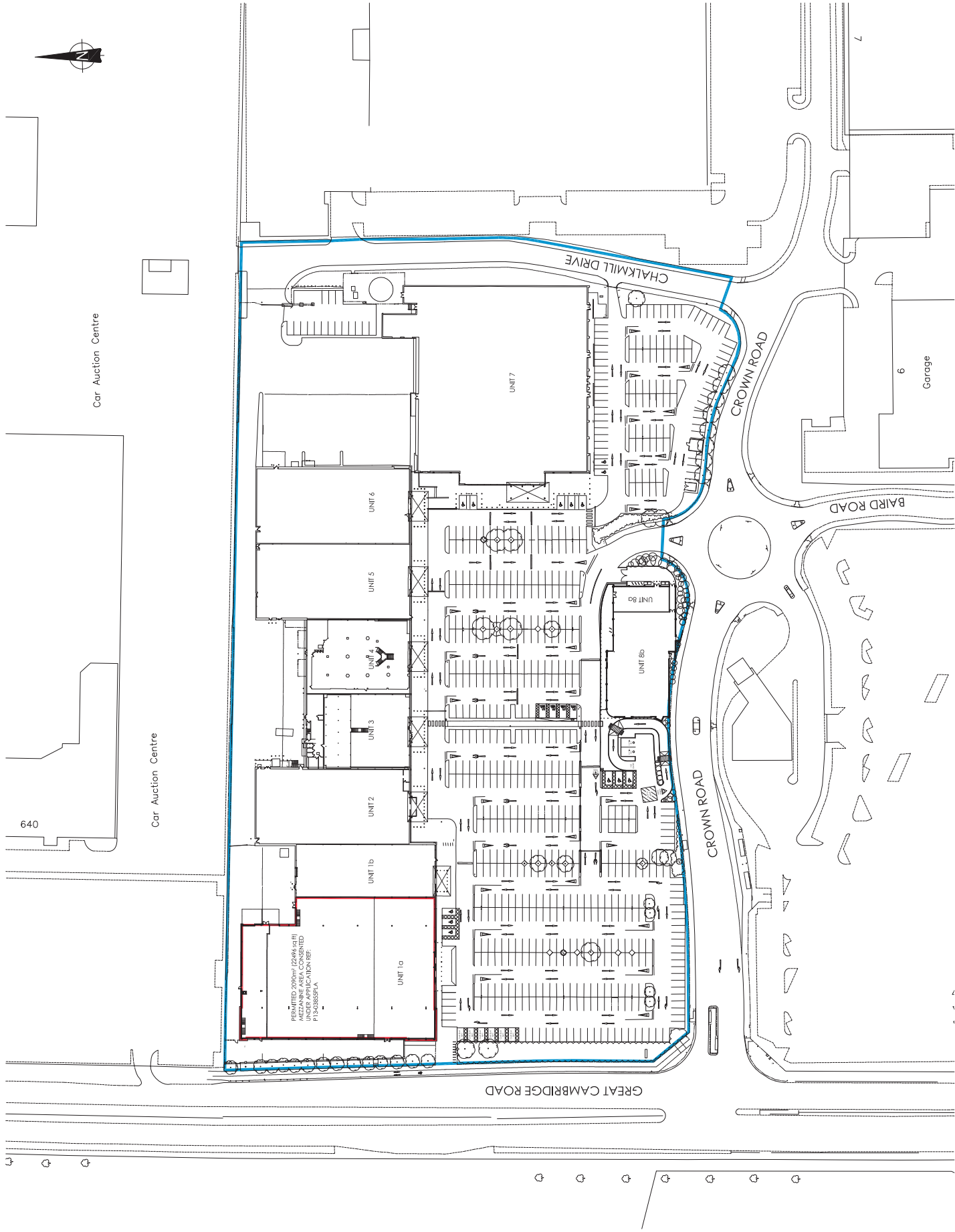

Revision	Description	Date
	URBANEDGE architecture / masterplanning / design	
Client	UNIVERSITIES SUPERANNUATION SCHEME	
Project	ENFIELD RETAIL PARK UNIT 1a	
Drawing	EXISTING SITE LOCATION PLAN	
Scale	1:1250 @ A3	Drawn TM
Date	MAY14	
Project No.	1348	Revision
Drawing No.	URB U1 [08]00 11	D00

This page is intentionally left blank